

SERIES CC, CARBON CANISTER HOUSINGS

ESG Series CC Carbon Canister Housings are designed to adsorb dissolved hydrocarbons, organics and certain well inhibitors. ESG Series CC Carbon Canister Housings are typically used on amine and glycol systems to remove the oils, dissolved hydrocarbons and degradation compounds that build up over time. Series CC Carbon units should be installed on the lean side of glycol and amine systems where the temperature is below 100-120°F and if placed on a slip stream they should be handling at least 30% of the total flow. Series CC Housings can be configured to have cartridges on a single layer or stacked two high. Single layer housings are easier to change out but stacked cartridge housings have a smaller foot print.

SPECIFICATIONS:

Orientation:	Vertical only
Inlet/Outlet Sizes:	1" to 8" standard
ANSI Ratings:	150# - 2500#
Number of Canisters:	1 to 19 (or 38 if canisters are stacked)
Service:	Sweet or Sour
Materials:	Carbon Steel
MDMT:	-20°F
Design Temperature:	Up to 150°F (higher temps possible)
Closure:	Swing-Bolt Standard

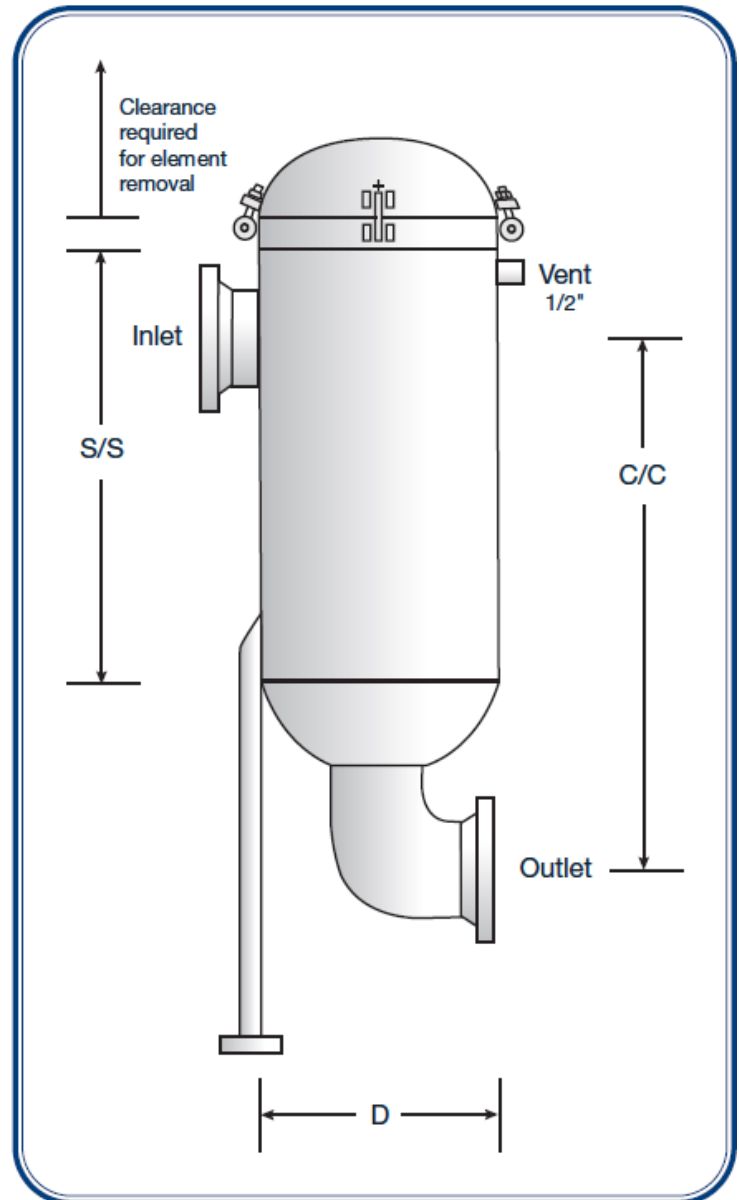

OPTIONS:

- 304 or 316 Stainless Steel housing or element posts.
- Low temp materials.
- Quick Opening Closure designs are available.
- All flanged construction.
- Single level cartridges or stacked cartridges.

HOW TO SPECIFY A MODEL:

EACC-S-01-12-01

ANSI RATING

A = 150#
 B = 300#
 C = 600#
 D = 900#
 E = 1500#
 F = 2500#

SERVICE

S = Sweet
 SS = Sour

INLET/OUTLET (in)

of CANISTERS

CASE SIZE (in)

ORIENTATION OPTIONS:

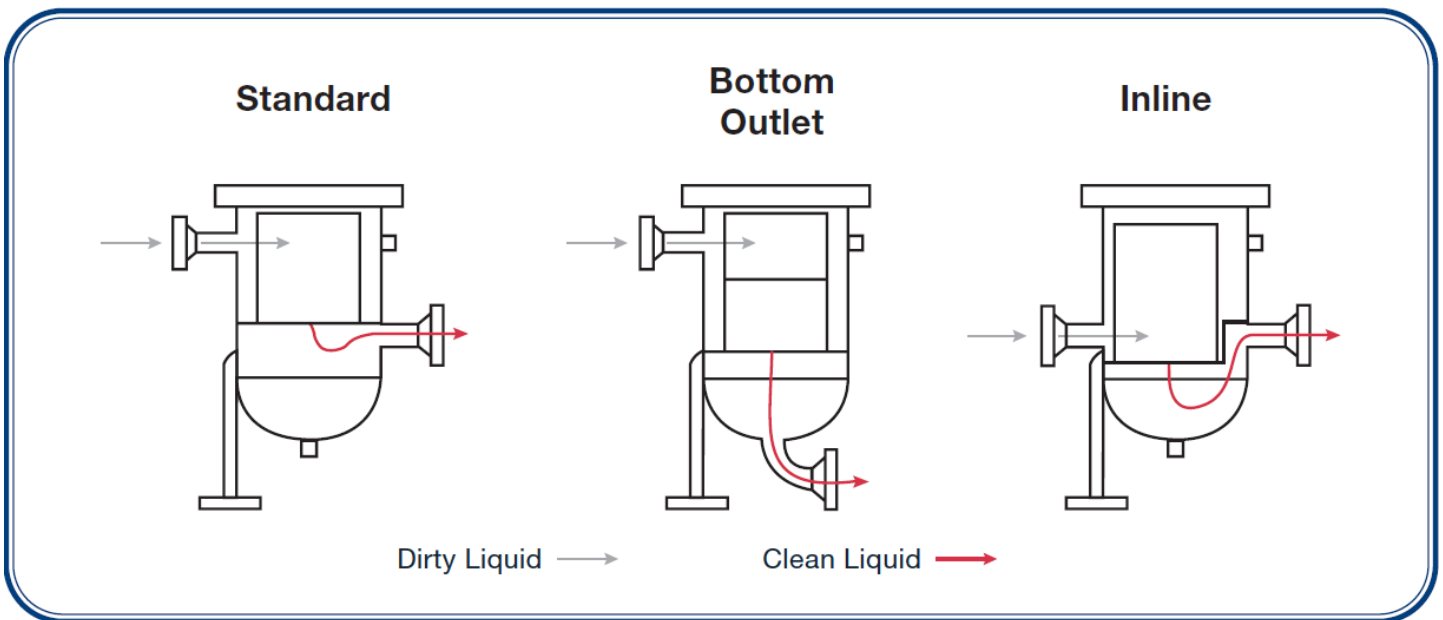

Contact Us:

Calgary
403-571-0202

Southern Alberta
403-863-7370

Edmonton
780-224-3052

Grande Prairie
780-518-4002

Fort McMurray
780-668-8935

Northern BC
780-518-4002

Southern BC
250-808-5548

Saskatchewan
306-717-1485

Eastern Canada
403-651-8817

Toll Free: 1-800-247-0202

esgfiltration.com

vessels@esgfiltration.com