



"A leading worldwide supplier of high efficiency filters for a variety of industries and applications."

OPERATION AND INSTALLATION INSTRUCTIONS

Warning

A filter housing is a pressure vessel, it must never be used above its stated maximum allowable working pressure and must be used within its stated temperature range. Ensure that these items are used in well-designed piping systems with suitable indicators to warn users and servicing personnel of the presence of pressure and high temperatures, wherever possible use pressure-limiting or safety devices. Remember that the pressure rating is reduced at high temperatures. Consult United Filtration for guidance.

It is the responsibility of the user to ensure that the materials of construction of the filter housing, gasket and filter media are suitable for the intended application. During every servicing, a visual inspection must be made of the surfaces of the housing for signs of corrosion, erosion or general wear. The housing must be removed from service if any of these signs are evident as there are no corrosion allowances used in the design of these filters. It is recommended that these filters not be used on unstable fluids.

Disposable microfiber elements are intended for final point-of-use or polishing filtration and must be protected by a pre-filter. Disposable elements are not designed to remove bulk contaminants on an ongoing basis. Monitoring of the filter element is essential for proper functionality.

The following items have **NOT** been taken into account during the design of the filter housing:

- Static pressure and mass of contents
- Traffic, wind and earthquake loading
- Reaction forces and moments resulting from mounting
- Decomposition of unstable fluids
- External fire

Comprehensive Installation Guide for All Filter Housings

A filter housing is a pressure vessel the system connections and accessory outlets must be leak tight. It is normally good practice to use a pipe sealant on the fittings prior to connecting to the filter housing ports. This will allow disassembly at a later time, if required. Any sealant such as PTFE tape, paste or other compound may be used if compatible with the filtered media. The torque value of the fittings will depend upon the quality of the fittings and the type of sealant used but should typically be between 30 FT-LB (Foot-Pound) and 55 FT-LB (Foot-Pound). Ensure the fittings get inspected during servicing and re-tightened if necessary. **It is not recommended that heads and bowls from different filter assemblies be swapped.**

T-Type Housings

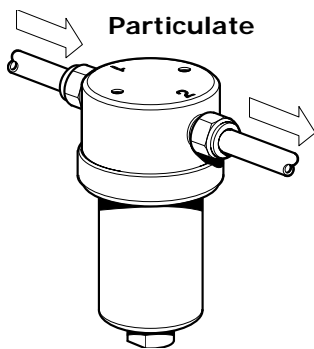

Particulate Gas Service

If the filter housing is being used to remove solid particulates from a gas or liquid, the flow direction through the filter element should be from **outside-to-inside** direction. Most housings have an arrow showing the correct direction. If the ports on the housing are numbered, port 1 is the inlet, and port 2 is the outlet.

Coalescing Gas Service

If the application is coalescing (removing liquids from gases) install the housing so the flow is in the opposite direction, **inside-to-outside** through the filter element. In this case port 2 is the inlet, and port 1 is the outlet. Suspended liquids in the air or gas will be coalesced and bleed from the outside of the filter element into the bowl of the housing in order to be drained (removed from the system). The liquid may be removed with manual or automatic drains.

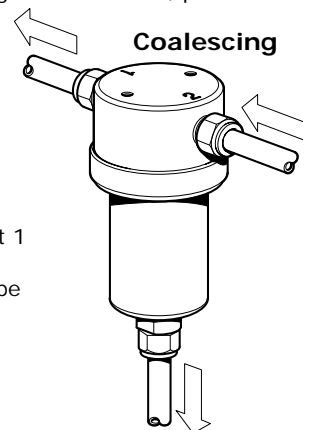

When installing filter housing and elements care should be taken to ensure the head and bowls are kept as a pair. It is not recommended that heads and bowls from different filter assemblies be swapped. Wherever possible, installation of filter housings should be made using an appropriate mounting bracket to avoid excessive loads on the piping. Brackets are also recommended to eliminate line/filter housing vibration. Filter housing must be installed in a tremble free system to function properly.

Changing the Filter Element

Ensure there is no pressure in the housing. Remove the bowl, element retainer and filter element.

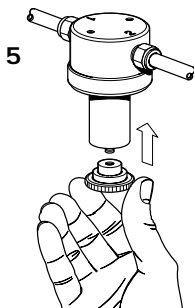
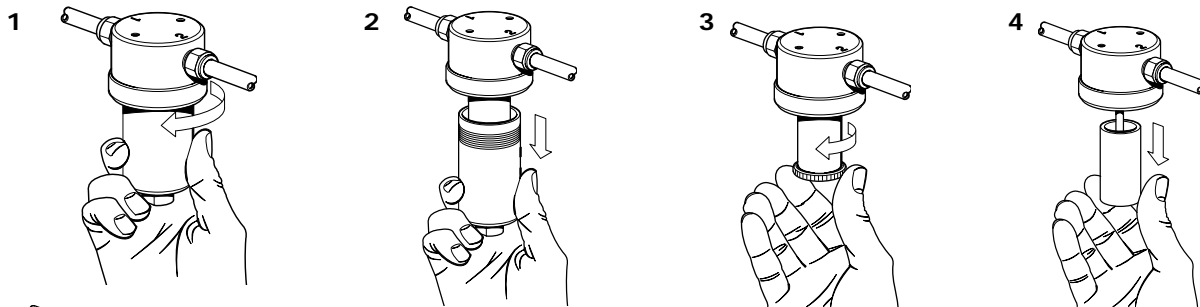

Disposable and sintered PTFE filter elements are sealed by compression against a flat surface. Gaskets are not required between the filter element and components of the housing. The stainless steel elements use a gasket at each end. The element is located by guides which fit the inside diameter of the tube at each end. In most housings the element is sealed by tightening a threaded element retainer.

The filter tube is securing sealed by tightening the element retainer a $\frac{1}{4}$ to 1 turn after it first contacts the filter element, the amount will depend on the housing type and element size. A mark on the end of the retainer is used as a guide.

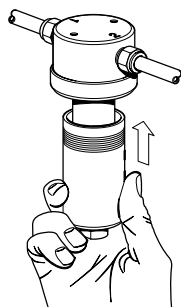
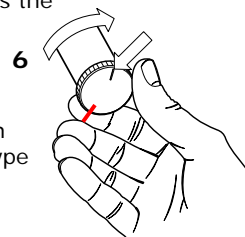

Before replacing the housing bowl ensure that the mating threads and sealing surfaces are clean and damage free. It is recommended that the threads and sealing faces are lubricated with a small amount of silicone grease before assembly. Stainless steel housings fitting with a solid PTFE gasket the bowl should be tightened to a torque of between 22 FT-LB and 30 FT-LB.

Grade 70C/70CS is a pneumatic grade coalescing filter. For instrument filtration, use a Grade 70C/70CS (prefilter), followed by a Grade 50C/50CS final filter with inside to outside flow on both housings.

Disposable microfiber elements are intended for final point-of-use or polishing filtration and must be protected by a pre-filter. Disposable elements are not designed to remove bulk contaminants on an ongoing basis. Monitoring of the filter element is essential for proper functionality.

Service Intervals

Our coalescing filters are designed to have an initial dry pressure drop of less than 2 PSI. Thereafter, the pressure drop will increase very slowly as solid particles are captured and retained in the capture layer of the element. Particles are captured throughout the depth of the element and therefore cannot be back flushed or cleaned in a solution. UFS recommends changing the filter element when the pressure drop reaches 10 PSI. An optional differential pressure indicator will give a visual warning of the need to change the filter element.

Make sure to shut off the line pressure before changing elements. **Note** that before resuming line pressure be sure that all port connections, the drain plug, and housing bowl are securely installed. All connections must be **LEAKTIGHT** to insure effective filtration as well as **SAFETY**. The user, through his own analysis and testing, is solely responsible for the product selection and ensuring all responsibility, safety and warning requirements of the application are met.

Ensure that gaskets are changed at suitable intervals. The interval time will depend on service and operating conditions, but it should be at least every three months.

Filter Elements

Filter elements must be monitored on a regular basis to ensure proper filtration, and to safeguard that the filter element regardless of type does not become overwhelmed by system upsets or just general conditions. If a filter element exhibits continual signs of failure or breakthrough, then either the element and/or housing is incorrect for the application, and corrective action must be taken immediately.

Disposable microfiber elements are intended for final point-of-use or polishing filtration and must be protected by a pre-filter. Disposable elements are not designed to remove bulk contaminants on an ongoing basis. Monitoring of the filter element is essential for proper functionality.

Recommended Lubricants

For standard applications we use and recommend Super Lube with PTFE which has a temperature range of -45°F to $+450^{\circ}\text{F}$. Fuchs Renolit ST-80 white lithium grease is suggested for applications with heavier loads, thread wear/seize and corrosion concerns may arise. In general lithium grease has a temperature range of -10°F to 300°F . For critical analytical applications we recommend Krytox since it does not off gas and is widely accepted as a critical application lubricant. Krytox GPL-220 series is good from -76°F to $+310^{\circ}\text{F}$ and Krytox XHT-AC is typically used with our heatable housings since it has an upper range of 400°F to 572°F .

DPI (Differential Pressure Indicator)

We offer two types of DPI kits:

The dome type with a yellow stem is set to rise from a 2 to 16 PSIG differential.

The Visual Differential Indicator is designated as "VDI" and is designed as a colored gauge with set points from 0 to 6.2 PSIG in the green range, 6.3 to 9.6 in the yellow range, and an end point of 14 PSIG in the red range.

Plastic 700 Series

Please follow the guidelines in this bulletin, plus keep in mind that our 700 series housings are constructed of various plastics (nylon, kynar, polypropylene, polycarbonate), which are easily stripped, and expanded if metal fittings are used or if the bowl is over tightened and "jumps" threads. If this occurs, do not use the filter housing since its integrity has been compromised.

Fast Loop

It's recommended that the Fast Loop filter be mounted in a vertical position with the removable end cap on top for ease of service. This will prevent liquids from spilling out while the filter element is being changed. Since the Fast Loop Filter is considered a pressure vessel all connections must be leak tight. When servicing the Fast Loop Filter ensure that there is no pressure in the line. Remove the cap by turning it counter clockwise until the cap can be removed. Replace the filter cartridge and then thread the cap back on clockwise until the threads bottom out. Note: There is no torque value associated with this housing.

Refer to "Comprehensive Installation Guide" for piping details.

Onstream Liquid Housings

Onstream Series Liquid Housings should be mounted in a vertical position. For leak tight service be sure to use a quality Pipe Sealant or PTFE Tape. When changing the filter element 1st turn off the supply of liquid and bleed the pressure from the line. Remove the top bolt by turning counter clockwise until the bowl can be lowered and then remove the cartridge. Once a new cartridge is installed into the bowl, carefully slide center rod through the head and tighten top nut counter clockwise to 30 Foot Pounds of Torque.

Refer to "Comprehensive Installation Guide" for piping details.

Heatable Housings

Since this series of filters is typically heated, the service intervals and O-ring life are considerably shorter than in traditional service. When servicing, be certain power to the heating jacket is disconnected, pressure or vacuum service is shut-off and the housing has cooled to room temperature to eliminate injury. We recommend cleaning and re-lubing the main O-ring on the bayonet handle during each element service. This will ensure proper sealing. If changing the element while the assembly is HOT, please use gloves to eliminate burns.

Refer to "Comprehensive Installation Guide" for piping details.

Membrane Separators

A membrane separator is a pressure vessel the system connections and accessory outlets must be leak tight. It is normally good practice to use a pipe sealant on the fittings prior to connecting to the membrane separator ports. This will allow disassembly at a later time, if required. Any sealant such as PTFE tape, paste or other compound may be used if compatible with the filtered media. The membrane separator cap is designed to be hand tighten until it bottoms out on the membrane body, 30 FT-LB (Foot-Pound) of torque will suffice in sealing this component. The torque value of the fittings will depend upon the quality of the fittings and the type of sealant used but should typically be between 30 FT-LB (Foot-Pound) and 55 FT-LB (Foot-Pound). Ensure the fittings get inspected during servicing and re-tightened if necessary. **It is not recommended that caps and bodies from different filter assemblies be swapped.**

For more technical information on Membrane Separators: <http://unitedfiltration.com/wp-content/uploads/Technical-Installation-Sheet-for-Membrane-Housings.pdf>

Explanation of Housing Labels

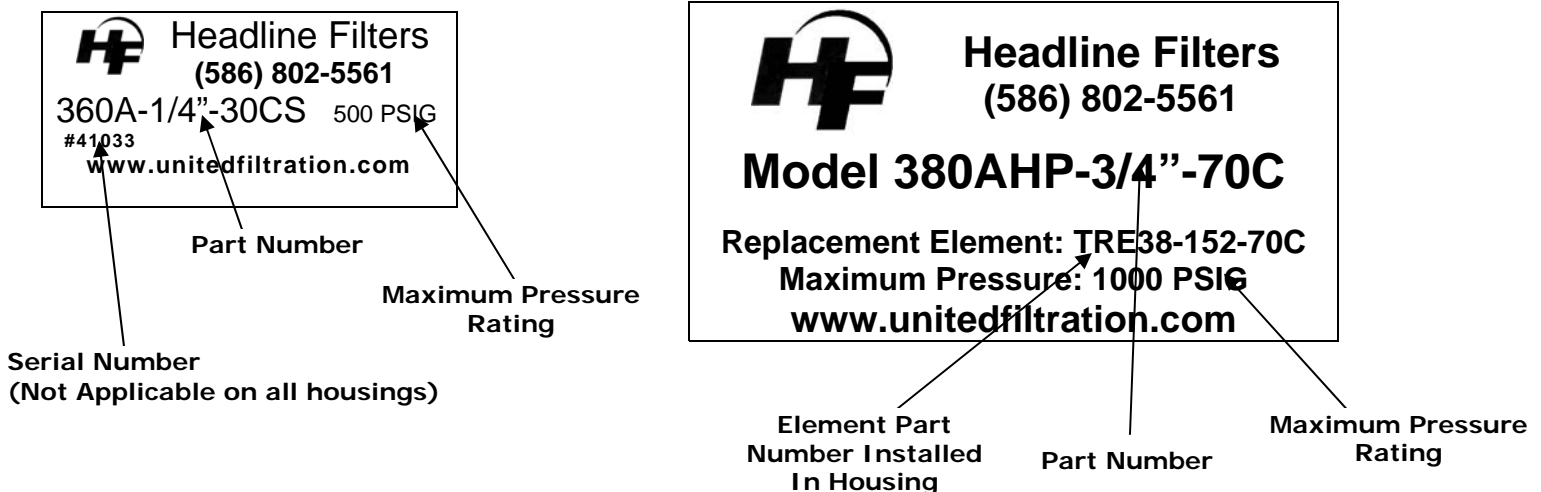

Warranty

United Filtration Systems warrants to Buyer that:

1. No goods will be nonconforming;
2. For a period of one year from the date of shipment of the goods (the Warranty Period), such goods will materially conform to the specifications set forth herein and on our website, and will be free from significant defects in material and workmanship; and
3. Buyer will receive good and valid title to the goods, free and clear of all encumbrances and liens of any kind. For purposes of this Transaction, the term nonconforming shall mean any goods received by Buyer from United Filtration Systems pursuant to a purchase order that
 - a. Do not conform to the part number listed in the applicable purchase order,
 - b. Do not significantly conform to the specifications we have provided you or which are on our website, or
 - c. Materially exceed the quantity of goods ordered by Buyer pursuant to this Transaction or any purchase order.

Warranty Limitations

The warranties under this Section do not apply where the goods have

1. Been subjected to abuse, misuse, neglect, negligence, accident, improper testing, improper installation, improper storage, improper handling, abnormal physical stress, abnormal environmental condition, or use contrary to any instructions issued by United Filtration Systems;
2. Been reconstructed, repaired, or altered by persons other than United Filtration Systems or its authorized representative; or
3. Been used with any third-party product, hardware, or product that has not been previously approved in writing by United Filtration Systems.

Exclusive Remedy For Defective Goods

Notwithstanding any other provision of this Transaction, this Limited Warranty contains Buyer's exclusive remedy for goods that do not conform to the warranties herein (Defective Goods). Buyer's remedy herein is conditioned on Buyer's compliance with its obligations herein. During the Warranty Period, regarding any allegedly Defective Goods:

1. Buyer shall notify United Filtration Systems, in writing, of any alleged claim or defect within ten business days from the date Buyer discovers, or on reasonable inspection should have discovered, such alleged claim or defect (but in any event before the expiration of the applicable Warranty Period);
2. Buyer shall ship, at Buyer's expense and risk of loss, the allegedly nonconforming goods to United Filtration Systems' facility designated by United Filtration Systems for inspection and testing by United Filtration Systems;
3. If United Filtration Systems' inspection and testing reveals, to United Filtration Systems' reasonable satisfaction, that such parts are Defective Goods, United Filtration Systems shall in its sole discretion, and at its expense, (a) repair or replace Defective Goods or (b) credit or refund the price of Defective Goods less any applicable discounts, rebates, or credits; and
4. If United Filtration Systems exercises its option to repair or replace, United Filtration Systems shall, after receiving Buyer's shipment of Defective Goods, ship to Buyer, at United Filtration Systems' expense and risk of loss, the repaired or replaced goods to the delivery location designated by United Filtration Systems.

Buyer has no right to return for repair, replacement, credit or refund any goods except as set forth in this Section. Neither United Filtration Systems nor Buyer shall be liable for incidental, punitive, exemplary, indirect or consequential damages, or lost profits arising under or relating to this transaction.

This section sets forth Buyer's sole remedy and United Filtration Systems' entire liability for any breach of the limited warranty set forth above. Further, any acceptance of this offer or resulting purchase order shall not change this limited warranty or the following disclaimer of implied warranties. In furtherance of this Limited Warranty and the Disclaimer of Implied Warranties below, this offer is limited to these terms.

DISCLAIMER OF IMPLIED WARRANTIES

EXCEPT FOR THE EXPRESS WARRANTIES SET ABOVE, UNITED FILTRATION SYSTEMS MAKES NO WARRANTY WHATSOEVER REGARDING THE GOODS, INCLUDING ANY (1) WARRANTY OF MERCHANTABILITY; (2) WARRANTY OF FITNESS FOR A PARTICULAR PURPOSE; (3) WARRANTY OF TITLE; OR (4) WARRANTY AGAINST INFRINGEMENT OF INTELLECTUAL PROPERTY RIGHTS OF A THIRD PARTY; WHETHER ARISING BY LAW, COURSE OF DEALING, COURSE OF PERFORMANCE, USAGE OF TRADE, OR OTHERWISE. BUYER ACKNOWLEDGES THAT IT HAS NOT RELIED ON ANY REPRESENTATION OR WARRANTY MADE BY UNITED FILTRATION SYSTEMS, OR ANY OTHER PERSON ON UNITED FILTRATION SYSTEMS' BEHALF, EXCEPT AS SPECIFICALLY HEREIN.

1001V